

SPECIFICATIONS

Power Input: 12 VAC/DC 40VA UL Listed Transformer (12 VAC is supplied by Pach & Company) or 12 VDC Power Supply (not supplied, power supply output voltage must be 13.5-14.5 VDC).

Current Consumption: 350 mA Idle, 475 mA operation.

Communication: RS-485 up to 4000 feet.

Night Light: Yellow LED Indicator/Green LED Indicator

Valid/Invalid Access: Green/Red or Yellow/Red and Buzzer

Operating Environment: Temp. 0° - 140° F

Relative Humidity: 0% to 95%.

Relay Output: From C Dry Contact 120 Vac 10A/ 24 VDC 10 A/ 250 Vac 7A.

Mounting: Surface

ONLY Support 4-Digit Code

Construction: 16 Gauge Cold Rolled Steel with Brushed Stainless Steel Faceplate.

Dimension: 6 6-1/8" (H) x 7-1/16" (W), 1-1/2" (D)

Shipping Weight: 5 Lbs.

OPERATIONS

System's ID number set by the DIP Switch



DIP SWITCH 123456 is satellite ID number (6 additional ID, not implemented yet)

DIP SWITCH 78 is Not applicable if the USCR purchased before September 2012 otherwise see table below

S1 DIP SWITCH SETTING			
DIP SWITCH 12345	ID#	DIP SWITCH 12345	ID#
11111	0	11110	16
01111	1	01110	17
10111	2	10110	18
00111	3	00110	19
11011	4	11010	20
01011	5	01010	21
10011	6	10010	22
00011	7	00010	23
11101	8	11100	24
01101	9	01100	25
10101	10	10100	26
00101	11	00100	27
11001	12	11000	28
01001	13	01000	29
10001	14	10000	30
00001	15	00000	31
78	Relay Time		
00	15 second		
01	8 second		
10	12 second		
11	4 second		

GREEN LED: Night light indicator

RED: Invalid card

GREEN LED: Valid card

**USKP
Satellite Keypad**



USKP is 26-Bit Satellite Keypad. It is compatible with all Quantum Series and AeGIS 9000 Series and AeGIS NPB 9000 Series.

- Parts below are included with the USCR
- Missing Parts, contact Pach and Company 1-888-678-7224
- Defective system under manufacturer warranty, call 1-888-678-7224 for advance replacement
- [24 Months warranty](#) for complete system, installation labor does not include on the warranty.
- [6 Months warranty](#) for Printed Circuit Board (USCRPCB). Installation labor does not include on the warranty
- Manual download at www.pach-co.com

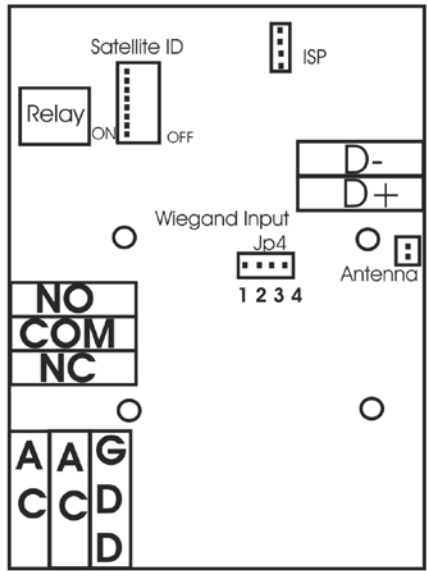

AC-AC= 12 VAC 40VA or 12VDC 2A
2-conductors, 16-18 gauge stranded wires

GDD= Earth Ground
1-conductor 14 gauge solid wire

D+ and **D-**= RS-485 Communication
2-conductors, 18 gauge shielded stranded wires

NC, COM, NO= Dry contact output for door strike, magnetic lock and gate operator
2-conductors, 18 gauge shielded stranded wires

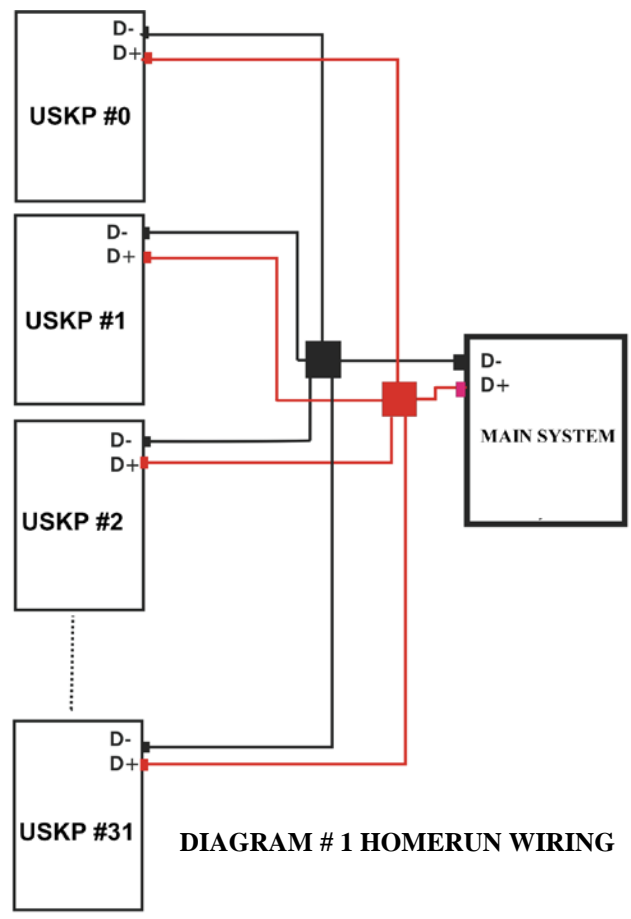

DIAGRAM # 1 HOMERUN WIRING

OPTIONAL 26-BIT WIEGAND INPUT Jp4
500 feet maximum, 4 conductor 18 gauge stranded wires

- Pin 1= 5 VDC
- Pin 2= GND
- Pin 3= D1 (Data 1)
- Pin 4= D0 (Data 0)

MUST INSTALL SAME READER MANUFACTURER AS THE MAIN SYSTEM. CONNECTOR IS REQUIRED. CONTACT PACH AND COMPANY BEFORE INSTALLING OPTIONAL CARD READER.

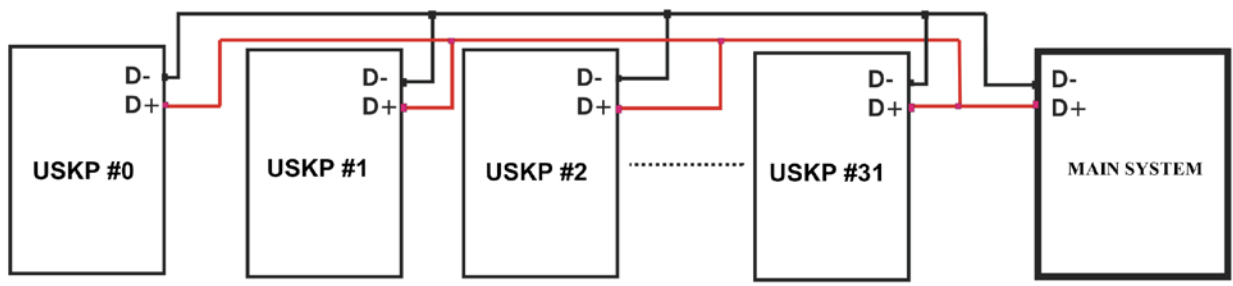

DIAGRAM # 2 DAISY-CHAIN WIRING